

Pickup Switch

For Railcars with two Pickups

Description

- In conjunction with decoder 76 150 the power supply loop is automatically switched to the front pickup of rail cars and Push-pull trains
- With 16 pole PluX and 4 pole SUSI interfaces

On Rail cars and Push-pull trains with two power pickups it is necessary to take power from the front pickup, otherwise accurate stopping before red signals will not function.

The pickup switch in conjunction with the decoder 76150 ensures that the power is always taken from the front Pickup according to the driving direction. So vehicles stop correctly at the signal and switching tracks trigger correctly.

The pickup switch has soldering connections for Pickup in front and in the back, motor, light front and back and two special functions.

The 4-pole SUSI interface can be used for connecting sound modules and LISSY mini-transmitters.

The decoder 76 150 with the 16-way PluX interface is easily plugged onto the pickup switch.

Dimensions: 40 x 20 x 10 mm

Connection

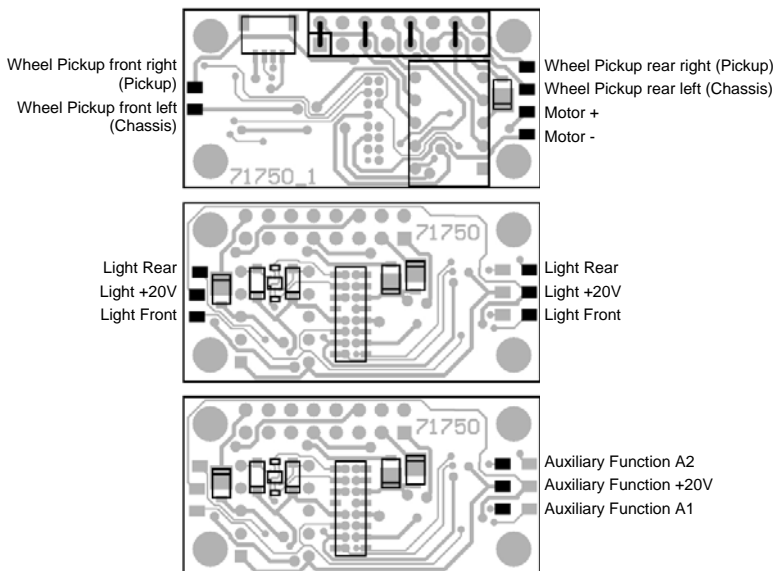

Guarantee declaration

Each component is tested for its complete functionality before distribution. If a fault should arise within the guarantee period of 2 years, we will repair the component free of charge upon production of proof of purchase. The warranty claim is void if the damage was caused by inappropriate treatment.

Please note that, according to EMV law, the component may be operated only within vehicles which carry the CE mark.

The trade names mentioned are registered trade marks of the respective companies

 **Uhlenbrock Elektronik**

Our contact Details: Service

In the event of a defect or failure send the unit together with the invoice and a short description of the fault back to us for repair.

Hotline

We are available if you have any questions!

Your direct line to a technician: **0 20 45 - 85 83 27**

Mon - Tue - Thu - Fri, 14:00-16:00 and Wed 16:00-18:00



Uhlenbrock Elektronik GmbH
Mercatorstr. 6
D-46244 Bottrop

Made in Germany

*Electronic devices do not
belong in household rubbish*



Part No. 71 750